

Simulated transfer path accuracy vs. sound perception

Giorgio PULVIRENTI⁽¹⁾, Nicolas TOTARO⁽¹⁾, Etienne PARIZET⁽¹⁾

¹Univ Lyon, INSA-Lyon, Laboratoire Vibrations Acoustique, F-69621 Villeurbanne, France, giorgio.pulvirenti@insa-lyon.fr

Abstract

The use of numerical methods is becoming more and more common in industry design processes. However, to finely represent the physics of the problem, numerical models are always more complex and time consuming. In the meantime, sound perception is now a very important topic for car manufacturers, who try to predict sound quality during the development phase of the vehicle. It is therefore useful to get some ideas about how accurate a simulation should be in order to be used in sound quality applications. The goal of this paper is to understand the minimum accuracy of simulated transfer paths (TPs) required to give meaningful psychoacoustic results. A physical model is build and the associated Finite Element (FE) model is setup, validated and taken as reference. Then, some deteriorations of the FE model are introduced and a sensitivity analysis checks how those changes affect objective metrics associated to the TPs. Laslty, hearing tests are performed in order to understand how people percieve the differencies in the various simulated sounds.

Keywords: Sound perception, Finite Elements, Tranfer Path, Transfer Function

1 INTRODUCTION

Sound quality is important for car manufacturers, for internal noise as well as external noise (beside noise regulation which are to be fulfilled). Simulation tools allow to predict the acoustic behaviour of a future car, but their accuracy is still a challenge for engineers. Indeed, despite the use of model order reduction, substructuring and other techniques, high accuracy still require long computation times, and remains problematic especially in some frequency bands [1].

A turning point is represented by the importance of human perception in both the problems of noise pollution and vehicle detection. Some authors investigated the role of frequency resolution of a Transfer Function (TF) into the perception of simulated sounds [2]. In [3], the effect of smoothing through moving averages was discussed. Recently, more sofisticated modifications have been examined. For instance, in [4] different modifications were applied depending on the frequency range. At low frequencies, inaccuracies about the right value of damping and eigenmodes were introduced; in the medium and high frequency range, decimation and two types of smoothing were considered. Outcomes of these researches are quite consistent and show that people do not perceive differences between two similar enough sounds.

These inabilities of people to detect details may be exploited to reduce the accuracy of simulated TFs, leading to significant reduction of computation time. In concrete terms, given a Transfer Path (TP) it is possible to derive several TFs by changing simulation parameters. Normally, TFs that represent more accurately the real TP are obtained with more time consuming simulations. Because humans are not able to detect all details, up to a certain threshold any increase of quality (of the TF) would be useless, thus making meaningless the use of very accurate (and expensive) simulations. In this case, effects of frequency resolution previously described may be directly applicable to simulations and the advantage in terms of saved time would be important. However, simulations have other sources of inaccuracy that could play a key role in this regards, and need to be investigated.

Purpose of the present work is to perform an introductory study about how numerical accuracy of the Transfer Path (TP) affects the perception of simulated sounds. The choice is to focus on the Finite Element (FE) Method as a tool for performing simulations and on the Infinite Elements (IFEs) to ensure Sommerfield radiation condition.

2 THE FINITE ELEMENT MODELS

A test mockup was build, then a FE model was designed and qualitatively validated. This allowed to have a numerical model that roughly has realistic acoustic properties. The mockup comprised a wood quarter-model car, assumed to be acoustically rigid. Its purpose was only to introduce non trivial acoustic TPs, so all details like suspensions and other structural components were not necessary and therefore missing. Figure 1 shows two views of the mockup, and figure 2 shows the multiview projections with its dimensions in mm.

The system has been tested in a semi-anechoic chamber. Four microphones were placed in touch with the tire, two of them on the ground and two of them suspended at 17.4cm from the ground. The monopole source used for exciting the system has been moved to four different positions, thus allowing to measure a total of sixteen Transfer Functions (TFs). The same TFs have been simulated in a CAE environment (Actran, [5]) through a FE model. Speed of sound and air density were set to the values of 347.7m/s and 1.177kg/m³ respectively.

Characteristic length of finite elements, h , was 3.7mm, the order of polynomial shape function p was 2. In order to ensure the Sommerfield radiation condition, Infinite Elements (IFEs) with shape function of order p_{IFE} 7 have been used. Figure 3 shows the comparison between measured (blue) and simulated (red) TFs. Precisely,

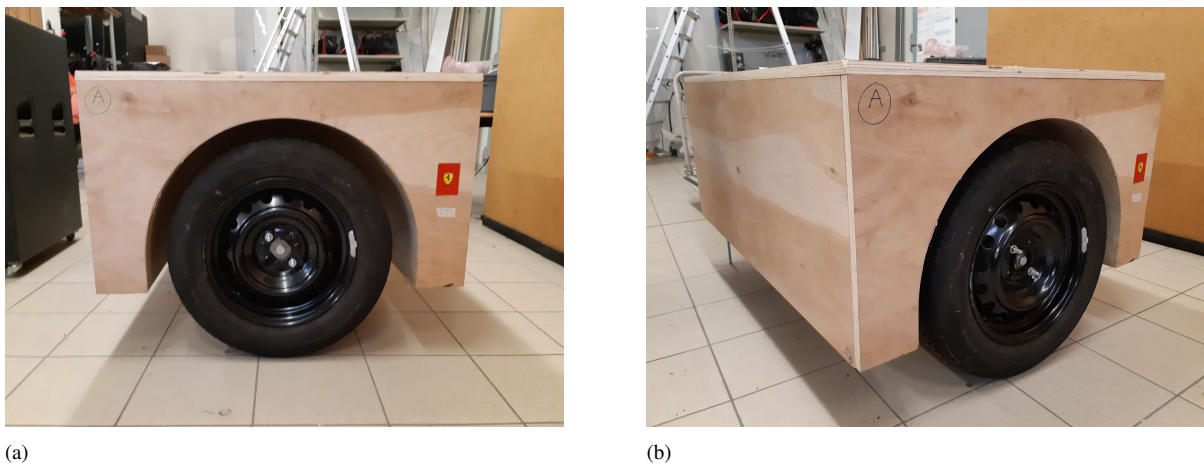

Figure 1. Two views of the mockup.

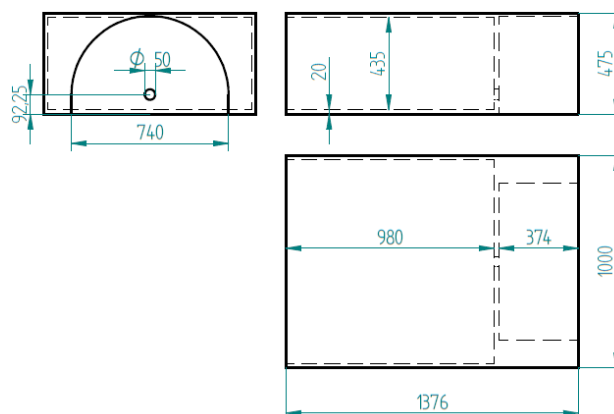

Figure 2. Multiview projections of the mockup; dimensions in mm.

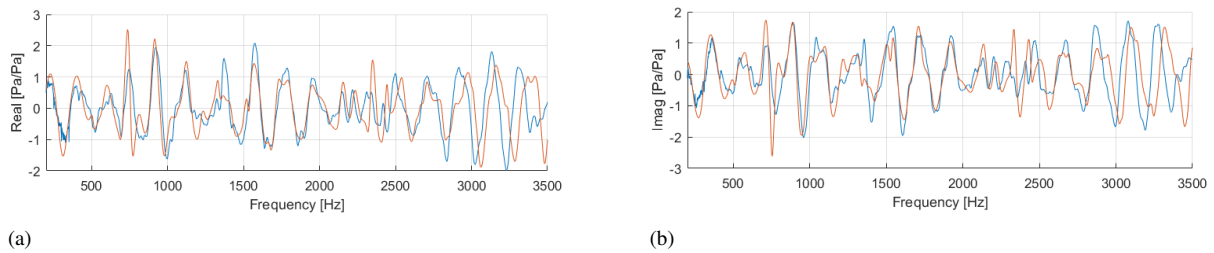

Figure 3. Real (a) and imaginary part (b) of measured (blue) and simulated (red) TFs.

figure 3(a) shows real parts and figure 3(b) shows imaginary parts. Despite the comparison not being perfect, it was considered sufficient for the purpose of this research.

Lastly, several FE models have been obtained by deteriorating the quality of the original mesh. Parameters h , p and p_{IFE} were the factors considered. Besides the original levels, other two were set for h (5.6mm and 11mm), one for p (1) and two for p_{IFE} (5 and 2), thus having a total of eighteen different models (including the reference one) and a total of 288 TFs.

3 SENSITIVITY ANALYSIS

For the sensitivity analysis, audio signals were used. They have been obtained by convoluting Impulse Response Functions (calculated from the TFs via Inverse Discrete Fourier Transform) with a tire noise signal. The latter was recorded during a coast-down with a constant deceleration of 1(km/h)/s on an experimental setup comprising the tire itself rolling on a bench with rough surface. Before convolution, the tire noise signal was cut between 52km/h and 48km/h

Two objective metrics were used to evaluate the simulated TFs, namely dBA values and loudness according to Moore and Glasberg's model, [6]. Differences with respect to reference values were calculated as well. In the case of dBA, differences were estimated as $D_{REF} - D$, with D being the dBA value of the considered sound and D_{REF} being the dBA value of the reference one. In the case of loudness, the discrepancies were estimated as the ratio L/L_{REF} , with obvious meaning of the terms. Level differences were very small between the different versions (maximum 1.2 dBA) as well as loudness differences as evaluated using Moore and Glasberg's method (maximum 10% difference), thus not providing any significant clue about human perception. Because of this, jury tests were performed.

For timing reasons, jury tests were performed with data of only one TP (the one of figure 3); they involved fourteen participants. Each participant has been asked to compare the reference sound with thirty six audio records. The latter ones were the first two seconds of the eighteen sounds associated to the Transfer Path (thus including the reference sound itself), which were compared twice in order to have redundant data. The two sounds of each pair were separated by a pause lasting 1 second. When comparing them, the participant was asked to rank the difference with a slider that can move between a "very similar" value and a "very different" one. The slider then produced values between 0 and 10, for very similar and very different sounds respectively. All the values relative to a single simulation have been averaged in order to obtain a ranking of the sounds as a function of their differences with the reference. Results are shown in table 1, and clearly indicate a significant importance of the polynomial shape function order p . h also seems to be important for the sound timbre, while the influence of p_{IFE} cannot be detected. Surprisingly, subjects reported a very slight difference between the reference sound and itself. Results are also represented in figure 4, in which the dashed vertical line separates simulations using $p=2$ (left-hand side) from simulations using $p=1$ (right-hand side). The shape of each point is associated to h : squares refer to $h=3.7$ mm, asterisks to $h=5.6$ mm and crosses to $h=3.7$ mm.

An ANOVA (repeated-measures) analysis was performed to better understand these results. Individually centered

Table 1. Factors level and averaged test scores, ranked in function of perceived similarity with the reference sound.

Rank	h [mm]	p _{IFE}	p	Score
1	3.7	7	2	0.45
2	3.7	5	2	0.56
3	5.6	5	2	0.67
4	5.6	7	2	0.9
5	3.7	2	2	1.73
6	5.6	2	2	2.05
7	11	5	2	3.47
8	11	7	2	3.86
9	11	2	2	3.92
10	3.7	7	1	6.06
11	3.7	2	1	6.34
12	3.7	5	1	6.84
13	5.6	7	1	7.1
14	5.6	2	1	7.3
15	5.6	5	1	7.54
16	11	2	1	8.08
17	11	7	1	8.1
18	11	5	1	8.15

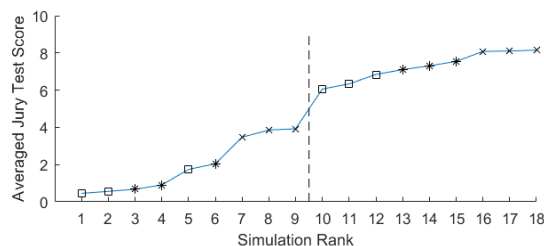

Figure 4. Averaged results of jury tests as a function of simulation rank.

data were used in order to avoid dependence of results' variances from the average differences. Outcomes made evident that p_{IFE} does not play a critical role, since its p-value is significantly higher than the usually accepted value 0.05. On the contrary, they confirmed the importance of p ($F(1,13)=149.1$, $p\text{-value}<0.00001$) and h ($F(2,26)=31.3$, $p\text{-value}<0.00001$). Figure 5 graphically represents the effects of p (a) and h (b) on the jury test score (as least square mean), with a 95% confidence interval.

4 CONCLUSIONS

A FE model was validated with a physical mockup and used as a reference in this research. Then, several FE models were generated by deteriorating the mesh quality of the reference. Loudness and dBA levels have been calculated, without obtaining significant differences among the various models. However, jury test results show clear differences depending in principle on the characteristic length of the FEs and on the order of their polynomial shape functions.

Certain simulations had similar scores, despite having different settings. Even if these results are just preliminary, they prompt a possible exploitation of psychoacoustic properties to properly set numerical models in order

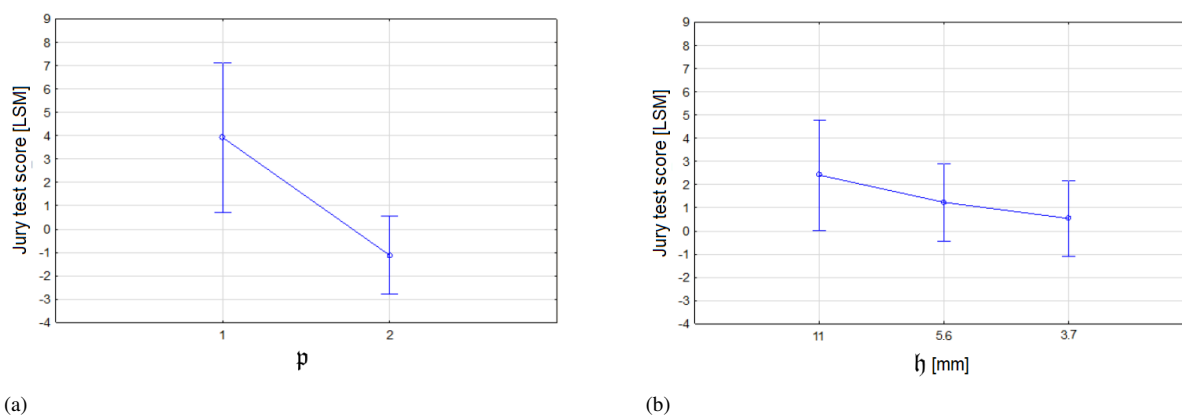

Figure 5. Effects of p (a) and h (b) on jury test score (least square means) with a 95% confidence interval.

to diminish computational time.

ACKNOWLEDGEMENTS

The authors gratefully acknowledge the European Commission for its support of the Marie Skłodowska Curie program through the ETN PBNv2 project (GA 721615).

This work was performed within the framework of the LABEX CeLyA (ANR-10-LABX-0060) of Université de Lyon, within the program «Investissements d’Avenir» (ANR-16-IDEX-0005) operated by the French National Research Agency (ANR).

REFERENCES

- [1] Desmet W. Mid-frequency vibro-acoustic modelling: challenges and potential solutions. Proceedings of ISMA 2002, Leuven, Belgium, 2002.
- [2] Trollé A.; et al. Auditory evaluation of sounds radiated from a vibrating plate inside a damped cavity: adjustment of the frequency resolution of vibro-acoustical computing. Acta Acustica united with Acustica, Vol 98 (3), 2011, pp 441-450.
- [3] Nykänen A.; et al. Assessment of the change in similarity judgements of auralized engine sounds caused by changes in frequency resolution of transfer functions. Applied Acoustics, Vol 72 (2-3), 2011, pp 115-123.
- [4] Aujogue N.; Parizet E. Influence of the Accuracy of Transfer Functions Description on the Perception of Auralised Sounds. SAE Technical Paper 2018-01-1490, 2018.
- [5] Actran 19.0, Free Field Technologies SA, 2019, Mont-Saint-Guibert Belgium.
- [6] Moore, B.; Glasberg, B. A revision of Zwicker’s Loudness Model. Acta Acustica united with Acustica, 1996, vol 82 (2), pp 335-345.