

In-plane Vibration and Tire Force Transmissibility owing to Tire Non-uniformity Defects

Zhe LIU¹; Kheirollah SEPAHVAND¹; Yintao WEI¹; Steffen MARBURG¹

¹ Department of Mechanical Engineering, Technical University of Munich, 85748 Garching, Germany

² Department of Automotive Engineering, State Key Lab Automotive Safety and Energy, Tsinghua University, Beijing, 100084, China

ABSTRACT

Tire non-uniformities give rise to rolling force variation at the spindle during steady state rolling. These kinds of characteristics are to some extent unavoidable. Therefore, limiting and managing the non-uniformities is of great economic importance to tire manufacturers. In this paper, an analytical model for predicting the high-speed uniformity and the force transmissibility using low-speed uniformity data is presented. The model is established based on a three-dimensional ring on an elastic foundation model. Considering the tire mass unbalance and the non-uniformity of the geometry, the variations of the force on the tire-road contacting area and the length of the footprint are analyzed. The mass and the geometrical non-uniformities are transformed into generalized forces and the equilibrium equations are solved in the space coordinate system. The length of the footprint caused by the non-uniformities is expanded by Fourier series, and the deformation is integrated to obtain the variation of the axial force. The method provides a possibility for the diagnosis and evaluation of high-speed tire dynamic characteristics.

Keywords: Tire non-uniformity, Vibration of tires, Force transmissibility, Three-dimensional ring model, Rolling kinematics

1. INTRODUCTION

Ride characteristics of passenger vehicles are affected by a variety of sources, including road roughness, structural transmission and drive system. It will cause the vibration in a wide frequency range. The overall driving vibration environment of the vehicle will also be influenced by the defects of the wheel, such as unbalanced mass distribution and uneven radial run-outs. Tire is an important component which generates and transmits the excitation in contact patch with road surface. But considering the complicated production process of tires which is inevitable to cause uncertainty of the tire structure, the dispersion of material and structural parameters will result in of the variations of the tyre dynamic force at the wheel rotation frequency.

The wheel unbalance and non-uniformity have been reported in several published studies to be the major causes of vehicle ride discomfort (1- 3). The perception of ride discomfort owing to the unbalanced vibration is predominantly in the low frequency range (<10Hz). The vibration caused by the non-uniformity defects of tire is related to the rotation speed. The radial run-out of a tire would yield appreciable vibration and tyre force variations at a frequency equal to twice the rotational speed (4, 5). However, most of the researches only focus on the experiment method and results (6, 7). Some existing analytical models (5, 8) are too simple to describe tire structural and geometric parameters.

Therefore, the purpose of this paper is to develop an analytical model for predicting the high-speed uniformity and the force transmissibility using low-speed uniformity data is presented. The model is established based on a three-dimensional ring on an elastic foundation model. Considering the tire mass unbalance and the non-uniformity of the geometry, the variations of the force on the tire-road contacting area and the length of the footprint are analyzed. The mass and the geometrical non-uniformities are transformed into generalized forces and the equilibrium equations are solved in the space coordinate system. The length of the footprint caused by the non-uniformities

¹ zhe.liu@tum.de

is expanded by Fourier series, and the deformation is integrated to obtain the variation of the axial force. The method provides a possibility for the diagnosis and evaluation of high-speed tire dynamic characteristics.

2. MODELING

2.1 Tire Ring Model

A tire was modeled in this paper. Figure 1 shows a deformable ring with a rectangular cross section on an elastic foundation (9). The tire is described by using cylindrical coordinates (r, θ, z) in the non-rotating coordinate system. The uniform pressure was applied on the inner wall. The side wall of the tire was equivalent to the elastic foundation. The elastic properties of the foundation are modeled respectively by distributed springs in the radial, circumferential and axial directions (k_u, k_v and k_w). The tread of a radial tire was modeled as a laminated composite ring considering the Timoshenko beam theory. A natural frequency analysis was created based on this model.

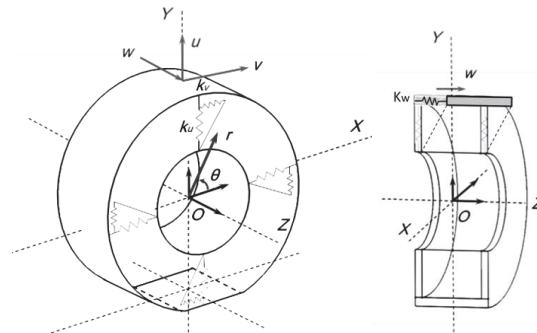

Figure 1 – Schematic of the laminated composite ring on an elastic foundation

This model can be simplified as a 2D in-plane model when only the in-plane vibration and force transmissibility is considered. The steady state response of the tire body under the concentrated forces can be written as follow.

$$\begin{aligned} v_b(\theta, t) &= \sum_{k=1}^{kc} \sum_{n=1}^{\infty} \left[\bar{A}_{n1} (Q_{vk} + (1+n^2)Q_{\beta k}) \cos n(\phi_0 - \phi) + \bar{A}_{n2} Q_{uk} \sin n(\phi_0 - \phi) \right] \\ u_b(\theta, t) &= \sum_{k=1}^{kc} \sum_{n=1}^{\infty} \left[-n\bar{A}_{n1} (Q_{vk} + (1+n^2)Q_{\beta k}) \sin n(\phi_0 - \phi) + n\bar{A}_{n2} Q_{uk} \cos n(\phi_0 - \phi) \right] \end{aligned} \quad (1)$$

Eq.(1) also can be transformed into a matrix form.

$$\mathbf{U} = \mathbf{T} * \mathbf{Q} \quad (2)$$

where, \mathbf{U} is the displacements of tire body; \mathbf{T} is the flexibility matrix; \mathbf{Q} is the matrix of generalized forces.

2.2 Contact Forces

The displacements of the tire body cannot be calculated in advance, because the tire body is not directly in contact with the rode surface. The displacements of the tire body and the tread rubber should be satisfied the geometry compatible conditions (10). Under a given overall deformation, the normal and tangential deformations of the tread rubber are:

$$\begin{aligned} u_s &= R_l \cos \eta + R_e \phi \sin \eta - (R + u_b) \cos \beta - v_b \sin \beta \\ v_s &= -R_l \sin \eta + R_e \phi \cos \eta + (R + u_b) \sin \beta - v_b \cos \beta \\ \eta &= \phi + \beta \end{aligned} \quad (3)$$

The forces acting on the rubber surface can be calculated.

$$\begin{aligned} F_{ns} &= k_{Es} (u_s - h_0) \\ F_{ts} &= k_{Gs} v_s \end{aligned} \quad (4)$$

The generalized forces and the tractions are obtained by using the coordination transformation.

$$\begin{Bmatrix} q_u(\phi) \\ q_v(\phi) \\ q_\beta(\phi) \end{Bmatrix} = \begin{bmatrix} \cos \beta & -\sin \beta \\ \sin \beta & \cos \beta \\ 0 & u_s \end{bmatrix} \begin{Bmatrix} F_{ns}(\phi) \\ F_{ts}(\phi) \end{Bmatrix} \quad (5)$$

$$\begin{Bmatrix} \sigma \\ \tau \end{Bmatrix} = \begin{bmatrix} \cos \eta & -\sin \eta \\ \sin \eta & \cos \eta \end{bmatrix} \begin{Bmatrix} F_{ns} \\ F_{ts} \end{Bmatrix} \quad (6)$$

Assuming the displacements of tire body are small. Substituting Eq.(3-4) into Eq.(5) and transforming to the matrix form, the linearized boundary equation is:

$$\mathbf{Q} = \mathbf{F} + \mathbf{H}\mathbf{Q} \quad (7)$$

The exact contact forces are obtained by successive substitution which is treated as the input of the rigid ring to calculate the transient responses.

2.3 Flexible-rigid Ring

Solving the partial differential equations of tire motion which is considered the large-deformation and the rotation effect will make the dynamic model complex (11). Therefore, the transient responses of tire body are approximated using a rigid ring to describe the first modes of tire body (<100Hz). The rigid ring represents the inertia of a tire.

The rigid ring is connected to the rim by 6-DOF spring. The contact forces generated by the flexible ring are the input load on the rigid ring to calculate the transient response. Then the position will be frozen and calculate the local deformation and the next-step contact forces of the tread rubber.

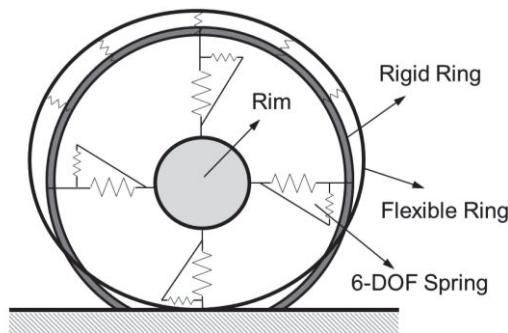

Figure 2 –Schematic of flexible-rigid ring model

2.4 Non-uniformity parameter

In this paper, the mass and the geometrical non-uniformities are considered. The unbalance concentrated mass is transformed into generalized forces and the equilibrium equations are solved in the space coordinate system. The uneven radial run-out, the geometrical non-uniformity, affects the parameter matrixes in the Eq. (7), and it also influences the contact forces.

3. PARAMETER IDENTIFICATION

To demonstrate the validity of this proposed theoretical model, a radial tire was modeled in this paper. The parameters of the flexible ring including the geometric and physical parameters will be identified from FEM model and engineering design parameters. As in the case study, the proposed new three-dimensional ring model is applied to the vibration modal analysis of the radial tire, 195/70R14. The parameters are listed in Table 1.

The parameters of the rigid ring and the stiffness parameters of the 6-DOF spring are identified by using the first modes results of the natural frequencies. The free vibration experiment should take into account the lateral modes. The cleat test and the static stiffness experiments also can be used to identify those parameters (11).

Table 1 –Parameters of a 195/70R14 radial tire

Parameter type	Unit	Numerical value
Ring width b	m	0.16
Ring thickness h	m	0.01
Internal pressure p_0	N/m ²	2.5×10^5
Effective density ρ	kg/m ³	2.28×10^3
Mean radius r	m	0.285
In-plane bending stiffness EI	N m ²	2.0
Radial distributed springs of sidewall k_u	N/m ²	6.3×10^5
Circumferential distributed springs of sidewall k_v	N/m ²	1.89×10^5
Tread band thickness h_0	m	0.0125
Tread normal stiffness k_{Es}	N/m	4.3×10^5
Tread tangential stiffness k_{Gs}	N/m	2.53×10^5

4. SIMULATION RESULTS

4.1 Contact Pressure Distribution

The results of contact force distribution under five different vertical load conditions are shown in Figure 3. It shows that the center part of the contact patch has a trend of buckling.

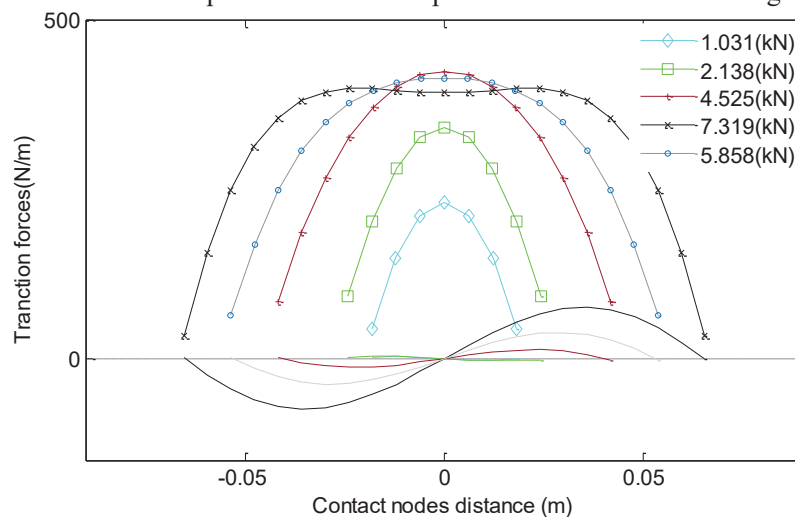

Figure 3 –The results of contact force distribution

4.2 Numerical Simulation Results

The results show that the vibration response caused by the mass imbalance mainly appears near the rotation angular frequency of the wheel, while the vibration response caused by the geometric non-uniformity of the tire appears near twice the rotation angular frequency of the wheel. At higher speeds, the effect of mass imbalance is more obvious, because the generalized force is directly related to the angular velocity of the wheel. The results suggest that under the excitation of flat road surface, the influence of wheel unbalance is the most pronounced, while on rough road surface, the influence gradually diminishes.

5. CONCLUSIONS

Tire non-uniformities give rise to rolling force variation at the spindle during steady state rolling. These kinds of characteristics are to some extent unavoidable. Therefore, limiting and managing the non-uniformities is of great economic importance to tire manufacturers. In this paper, an analytical model for predicting the high-speed uniformity and the force transmissibility using low-speed uniformity data is presented. The model is established based on a three-dimensional ring on an elastic foundation model. Considering the tire mass unbalance and the non-uniformity of the geometry, the

variations of the force on the tire-road contacting area and the length of the footprint are analyzed. The mass and the geometrical non-uniformities are transformed into generalized forces and the equilibrium equations are solved in the space coordinate system. The length of the footprint caused by the non-uniformities is expanded by Fourier series, and the deformation is integrated to obtain the variation of the axial force. The method provides a possibility for the diagnosis and evaluation of high-speed tire dynamic characteristics.

ACKNOWLEDGEMENTS

The authors acknowledge the support from the China Scholarship Council (CSC).

REFERENCES

1. Long WC. Factors Affecting Performance of Hubs, Drums, Wheels, and Rims on Truck Tractors and Trailers. SAE Technical Paper; 1965 Feb 1.
 2. Kenny TM. Quantifying tire, Rim, and vehicle effects on ride quality. SAE Technical Paper; 1989 Feb 1.
 3. Stutts DS, Krousgrill CM, Soedel W. Parametric excitation of tire-wheel assemblies by a stiffness non-uniformity. *Journal of sound and vibration*. 1995 Jan 19;179(3):499-512.
 4. Cebon D. Interaction between heavy vehicles and roads. SAE Technical Paper; 1993 Mar 1.
 5. Deodhar A, Rakheja S, Bhat RB. Vibration and tyre force transmissibility of commercial vehicles owing to wheel unbalance and non-uniformity defects. *International Journal of Heavy Vehicle Systems*. 2006 Jan 1;13(3):212-40.
 6. Kim KW, Park JB, Lee SJ. Tire mass imbalance, rolling phase difference, non-uniformity induced force difference, and inflation pressure change effects on steering wheel vibration. SAE Technical Paper; 2005 May 16.
 7. Dorfi HR. Tyre non-uniformities: comparison of analytical and numerical tyre models and correlation to experimentally measured data. *Vehicle system dynamics*. 2005 Jan 1;43(sup1):223-40.
 8. Dillinger BL, Jalili N, Ul Haque I. Analytical modelling and experimental verification of tyre non-uniformity. *International journal of vehicle design*. 2008 Jan 1;46(1):1-22.
 9. Liu Z, Zhou F, Oertel C, Wei Y. Three-dimensional vibration of a ring with a noncircular cross-section on an elastic foundation. *Proceedings of the Institution of Mechanical Engineers, Part C: Journal of Mechanical Engineering Science*. 2018 Jul;232(13):2381-93.
 10. Kim SJ, Savkoor AR. The contact problem of in-plane rolling of tires on a flat road. *Vehicle System Dynamics*. 1997 Jan 1;27(S1):189-206.
 11. Kim S, Nikravesh PE, Gim G. A two-dimensional tire model on uneven roads for vehicle dynamic simulation. *Vehicle system dynamics*. 2008 Oct 1;46(10):913-30.
-